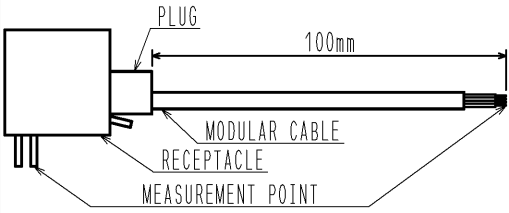

APPLICABLE STANDARD		① ANSI/TIA/EIA-568-B.2.10 CAT6a		
RATING	OPERATING TEMPERATURE RANGE	① -25 °C TO 60 °C	STORAGE TEMPERATURE RANGE	-25 °C TO 60 °C
	VOLTAGE	125 V AC	OPERATING HUMIDITY RANGE	95 % MAX
	CURRENT	1 A	APPLICABLE CABLE	AWG# 24 ~ AWG# 27

SPECIFICATIONS

ITEM	TEST METHOD	REQUIREMENTS	QT	AT
CONSTRUCTION				
GENERAL EXAMINATION	VISUALLY AND BY MEASURING INSTRUMENT.	ACCORDING TO DRAWING.	X	X
MARKING	CONFIRMED VISUALLY.		X	X

ELECTRIC CHARACTERISTICS				
CONTACT RESISTANCE	100 mA (DC OR 1000 Hz AC).	50 mΩ MAX.	X	X
				
INSULATION RESISTANCE	100 V DC.	100 MΩ MIN.	X	X
VOLTAGE PROOF	500 V AC FOR 1 min.	NO FLASHOVER OR BREAKDOWN.	X	X

MECHANICAL CHARACTERISTICS				
MECHANICAL OPERATION	200 TIMES INSERTIONS AND EXTRACTIONS.	1)CONTACT RESISTANCE: 70 mΩ MAX. 2)NO DAMAGE, CRACK AND LOOSENESS, OF PARTS.	X	—
VIBRATION	FREQUENCY 10 TO 55Hz, SINGLE AMPLITUDE 0.75 mm, AT 2h, FOR 3 DIRECTIONS.	1)NO ELECTRICAL DISCONTINUITY OF 1 μs. 2)CONTACT RESISTANCE: 70 mΩ MAX. 3)NO DAMAGE, CRACK AND LOOSENESS, OF PARTS.	X	—
SHOCK	490 m/s ² DIRECTIONS OF PULSE 11 ms AT 3 TIMES FOR 6 DIRECTIONS.		X	—

ENVIRONMENTAL CHARACTERISTICS				
DAMP HEAT (STEADY STATE)	EXPOSED AT 40 °C, 90 TO 95 %, 500h.	1)CONTACT RESISTANCE: 70 mΩ MAX. 2)INSULATION RESISTANCE: 1 MΩ MIN.(AT HIGH HUMIDITY) 10MΩ MIN.(AT DRY) 3)NO DAMAGE, CRACK AND LOOSENESS, OF PARTS.	X	—
RAPID CHANGE OF TEMPERATURE	TEMPERATURE: -55 → 15 TO 35 → 85 → 15 TO 35 °C TIME: 30 → 2 TO 3 → 30 → 2 TO 3 min. UNDER 5 CYCLES.	1)CONTACT RESISTANCE: 70 mΩ MAX. 2)INSULATION RESISTANCE: 100 MΩ MIN. 3)NO DAMAGE, CRACK AND LOOSENESS, OF PARTS.	X	—
CORROSION SALT MIST	EXPOSED IN 5 % SALT WATER SPRAY FOR 48 h.	1)CONTACT RESISTANCE: 70 mΩ MAX. 2)NO DAMAGE, CRACK AND LOOSENESS, OF PARTS.	X	—

- ① THE OPERATION TEMPERATURE INCLUDES THE TEMPERATURE RISE BY CURRENT CARRYING.
 ② TEMPERATURE RANGE FOR A CONNECTOR UNMATED.
 ③ USE UNDER THE CONDITION RECOMMENDED BY A CABLE MANUFACTURE.

COUNT	DESCRIPTION OF REVISIONS	DESIGNED	CHECKED	DATE
① 2	DIS-E-002799	MT. ITANO	KI. NAGANUMA	09.05.29

REMARK	APPROVED	YH. ENAMI	09.01.26
	CHECKED	YH. ENAMI	09.01.26
	DESIGNED	MT. ITANO	09.01.26
	DRAWN	MT. ITANO	09.01.26

Unless otherwise specified, refer to JIS C 5402.

Note QT:Qualification Test AT:Assurance Test X:Applicable Test	DRAWING NO.	ELG4-126868-00
--	-------------	----------------

HRS	SPECIFICATION SHEET	PART NO.	TM31P-TM-88P
	HIROSE ELECTRIC CO., LTD.	CODE NO.	CL222-4626-7-00

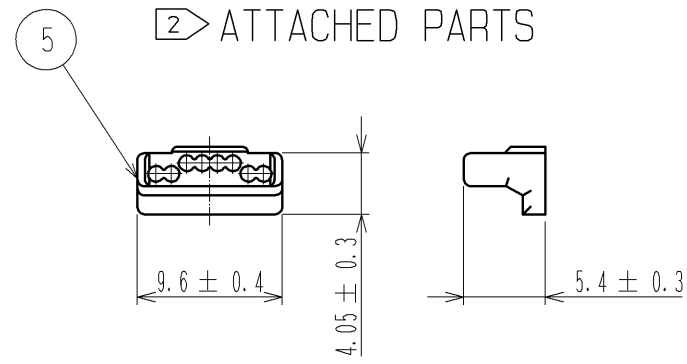
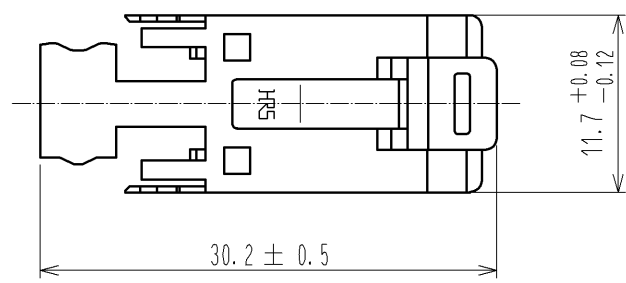

1 TABLE-1

APPLICABLE CABLE WIRE		
	CONDUCTOR	AWG#24 STRANDED WIRE ~ AWG#27 STRANDED WIRE
	INSULATOR DIAMETER	($\phi 0.9 \sim \phi 1.0$)
	JACKET DIAMETER	($\phi 5.8 \sim \phi 6.0$)

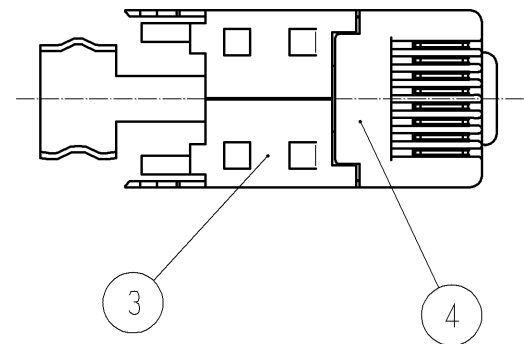
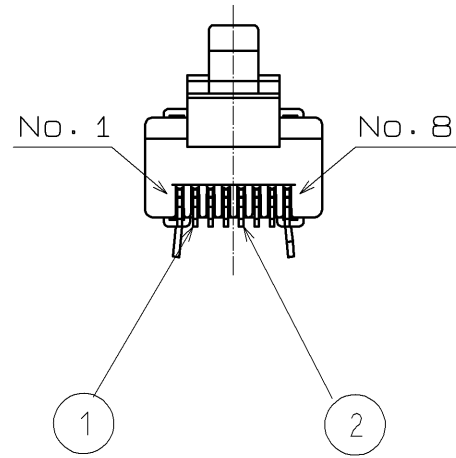
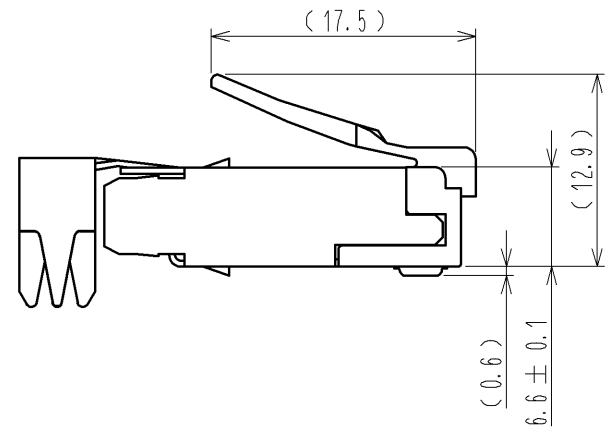

5 CL222-2862-9-**
TM21P-88P(**)

COVER(SOLD SEPARATEIL)MATED

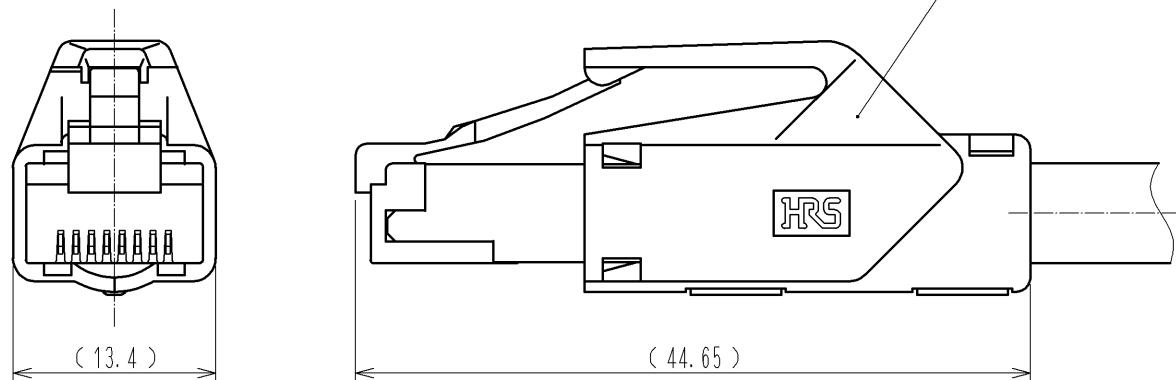

- NOTES
- 1 APPLICABLE CABLE IS SHOWN IN TABLE-1
 - 2 PLEASE USE ACCESSORY AS A GUIDE PLATE AND ASSEMBLE CONNECTOR WITH CABLE INSERTING ACCESSORY INTO CONNECTOR.
 - 3 () INDICATES THE REFERENCE DIMENSIONS.
 - 4 TO SATISFY CAT6a PERFORMANCE, PLEASE ASSEMBLE ACCORDING TO HRS INSTRUCTION. (ETAD-E2847)
 - 5 COLORS ARE DIFFERENT DEPENDING ON THE SPECIFICATION NUMBER.

2	PHOSPHOR BRONZE	CONTACT: GOLD PLATING 1.27 μ m MIN LEAD: GOLD PLATING 0.03 μ m MIN UNDER: NICKEL PLATING 2 μ m MIN						
1	PHOSPHOR BRONZE	CONTACT: GOLD PLATING 1.27 μ m MIN LEAD: GOLD PLATING 0.03 μ m MIN UNDER: NICKEL PLATING 2 μ m MIN	5	POLYCARBONATE	(YELLOW)UL94V-2			
			4	POLYCARBONATE	(YELLOW)UL94V-2			
			3	STAINLESS STEEL	OVER:NICKEL PLATING 0.5 μ m MIN			
NO.	MATERIAL	FINISH . REMARKS	NO.	MATERIAL	FINISH . REMARKS			
UNITS mm		SCALE 2 : 1		COUNT	DESCRIPTION OF REVISIONS	DESIGNED	CHECKED	DATE
HRS HIROSE ELECTRIC CO., LTD.		APPROVED : YH. ENAMI 09.01.26	DRAWING NO. EDC3-126868-00					
		CHECKED : YH. ENAMI 09.01.26	PART NO. TM31P-TM-88P					
		DESIGNED : MT. ITANO 09.01.26	CODE NO. CL222-4626-7-00					
		DRAWN : MT. ITANO 09.01.26						